

Hydro Speed Regulators

Hydro speed regulators are designed to control the forward speed (feed rate) of the Selffeeder. Use of a regulator provides adjustable feed rates, faster cycle times, reduces burring, eliminates drill breakage, and prevents sudden forward surges at drill breakthrough. One regulator is required per Selffeeder for drilling operations. Choose from the Spring-return type shown below or the Air-return type shown on page 24.

Spring Return Type 'RB'

Spring loaded regulators are used primarily for standard drilling operations and are designed to automatically return to their position at the end of every drilling cycle.



With the RB spring return regulator, the piston rod is automatically returned to its original position by the built-in spring when the piston rod is no longer loaded.

Features:

1. The Regulator is completely sealed to eliminate the need for resupplying the unit with operating oil and will provide stable speed control for many years of production.
2. Installation is easy. No need for piping or wiring.

Specifications

Model	Applicable Electric Selffeeder	Max. Stroke in. (mm)	Load Range lbs. (kg)	Range of Speed Control for Each Thrust		Permissible Impact Load Ft. Lbs. (kg•m)	Wgt. (Main Body Only)
				in./sec.	(mm/sec)		
RB-2430	ES2	1.18 (30)	44 - 330	F = 44 Lbs. :.01 - .20	F = 20kg : 0.1 - 5	1.80 (0.25)	.90 (0.41)
RB-2460	ES3C ES3P	2.36 (60)	(20 - 150)	F = 110 Lbs. :.01 - 1.00 F = 220 Lbs. :.02 - 1.57 F = 330 Lbs. :.02 - 2.00	F = 50kg : 0.2 - 25 F = 100kg : 0.3 - 40 F = 150kg : 0.4 - 50		
RB-3140	ES5	1.57 (40)	110 - 660	F = 110 Lbs. :.01 - .40	F = 50kg : 0.1 - 10	2.90 (0.4)	2.09 (0.95)
RB-3160		2.36 (60)	(50 - 300)	F = 330 Lbs. :.01 - 1.00 F = 480 Lbs. :.02 - 1.38 F = 660 Lbs. :.02 - 1.57	F = 150kg : 0.2 - 25 F = 220kg : 0.3 - 35 F = 300kg : 0.5 - 40		2.64 (1.20)
RB-3860	ES6	2.36 (60)	480 - 990 (220 - 450)	F = 480 Lbs. :.01 - .59 F = 840 Lbs. :.01 - .98 F = 990 Lbs. :.02 - 1.18	F = 220kg : 0.2 - 15 F = 380kg : 0.3 - 25 F = 450kg : 0.4 - 30	4.30 (0.6)	3.96 (1.80)

Dimensions: Inches (mm)

RB-2430, RB-2460, RB-3140, RB-3160

RB-3860

Model	Applicable Electric Selffeeder	A	B	C	D	E	F	G	H	I	J	K	L	M	N
RB-2430	ES2	4.53 (115)	1.10 (28)	.94 (24)	.35 (9)	.79 (20)	1.26 (32)	1.18 (30)	7.87 (200)	1.34 (34)	1.73 (44)	.20 (5)	.59 (15)	1.18 (30)	M5 x 0.8
RB-2460	ES3C ES3P	7.72 (196)						2.36 (60)	12.24 (311)						
RB-3140	ES5	5.91 (150)	1.42 (36)	1.22 (31)	.47 (12)	.94 (24)	1.57 (40)	1.57 (40)	10.63 (270)	1.65 (42)	2.28 (58)	.28 (7)	.79 (20)	1.57 (40)	M6 x 1
RB-3160		7.48 (190)						2.36 (60)	13.03 (331)						
RB-3860	ES6	6.50 (165)	1.73 (44)	1.50 (38)	0.55 (14)	1.34 (34)	1.97 (50)	2.36 (60)	13.78 (350)	1.65 (42)	1.50 (38)	3.70 (94)	.94 (24)	1.93 (49)	.28 (7)

1. Clamping blocks for regulators are available as an option.

Ordering Example:

One 2.36" stroke Spring Return Regulator & Clamp for Model ES5 Selffeeder.

Qty. 1 - RB-3160 Regulator with Clamp

Air Return Type 'R'

'R' Air return regulators serve the same function as the spring return type in that they control the forward speed of the drill. However, the air type requires an air signal at the end of each drilling cycle to return the regulator to its original position. Also, these regulators are required for peck feed drilling as they are capable of holding the drilling depth at the end of each peck feed motion.

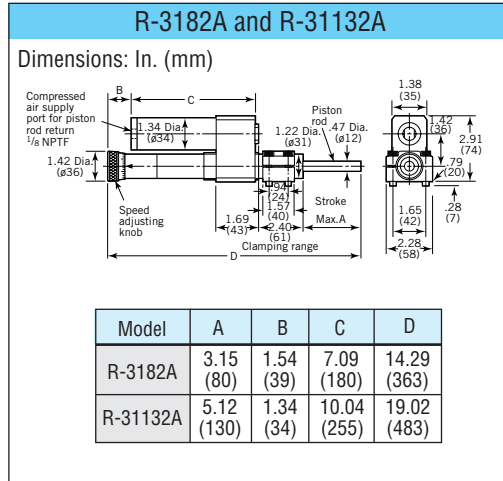
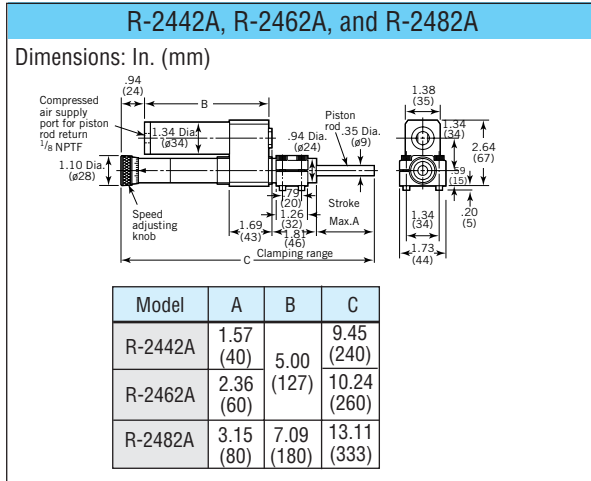

Specifications

Model	Applicable Selffeeder	Max. Stroke in. (mm)	Load Range Lbs. (kg)	Range of Speed Control for Each Thrust		Permissible Impact Load Fl. Lbs. (kg·m)	Wgt. (Main Body Only)
				in./sec.	(mm/sec)		
R-2442A	ES2 ES3C ES3P	1.57 (40)	44 - 330 (20 - 150)	F = 44 Lbs. : .01 - .20	F = 20kg : 0.3 - 5	1.80 (0.25)	2.86 (1.3)
R-2462A		2.36 (60)		F = 220 Lbs. : .02 - .98	F = 100kg : 0.5 - 25		3.08 (1.4)
R-2482A		3.15 (80)		F = 330 Lbs. : .03 - 1.18	F = 150kg : 0.8 - 30		3.30 (1.5)
R-3182A	ES5	3.15 (80)	110 - 660 (50 - 300)	F = 220 Lbs. : .01 - .47	F = 100kg : 0.3 - 12	2.90 (0.4)	4.85 (2.2)
R-31132A		5.12 (130)		F = 480 Lbs. : .02 - .98	F = 220kg : 0.5 - 25		6.17 (2.8)
R-38100AC	ES6	3.94 (100)	480 - 990 (220 - 450)	F = 480 Lbs. : .01 - .59	F = 220kg : 0.3 - 15	4.30 (0.6)	9.26 (4.2)
R-55100A	ES7	3.94 (100)	880 - 2200 (400 - 1000)	F = 840 Lbs. : .02 - .98	F = 380kg : 0.5 - 25	7.20 (1.0)	16.09 (7.3)
R-55150A		5.91 (150)		F = 990 Lbs. : .03 - 1.18	F = 450kg : 0.8 - 30		17.86 (8.1)

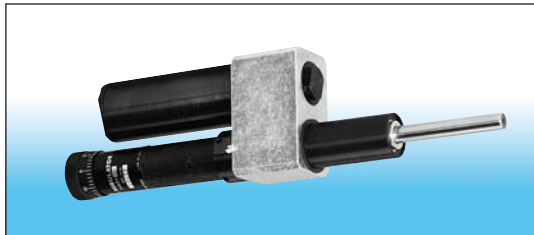
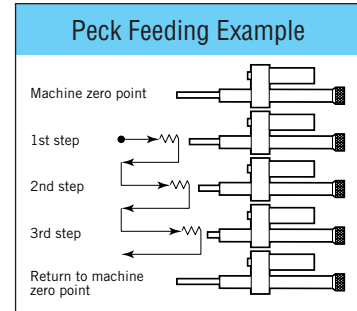

Features:

1. With the position of the piston rod maintained along the stroke as desired, efficient peck feed drilling is possible.
2. Longer strokes available for extended application purposes.

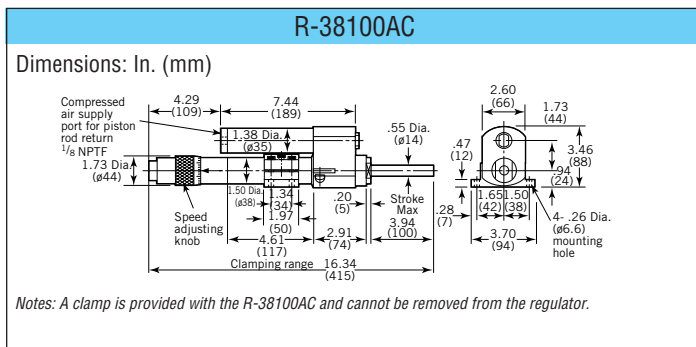
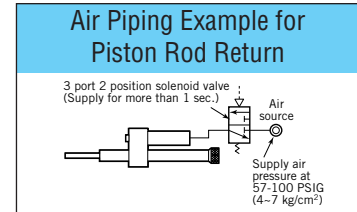

Ordering Example:

One 3.15" stroke Air Return Regulator for Model ES5 Selffeeder.

Qty. 1 - RB-3182A Air Return Regulator.

